

BRACKET BH5A

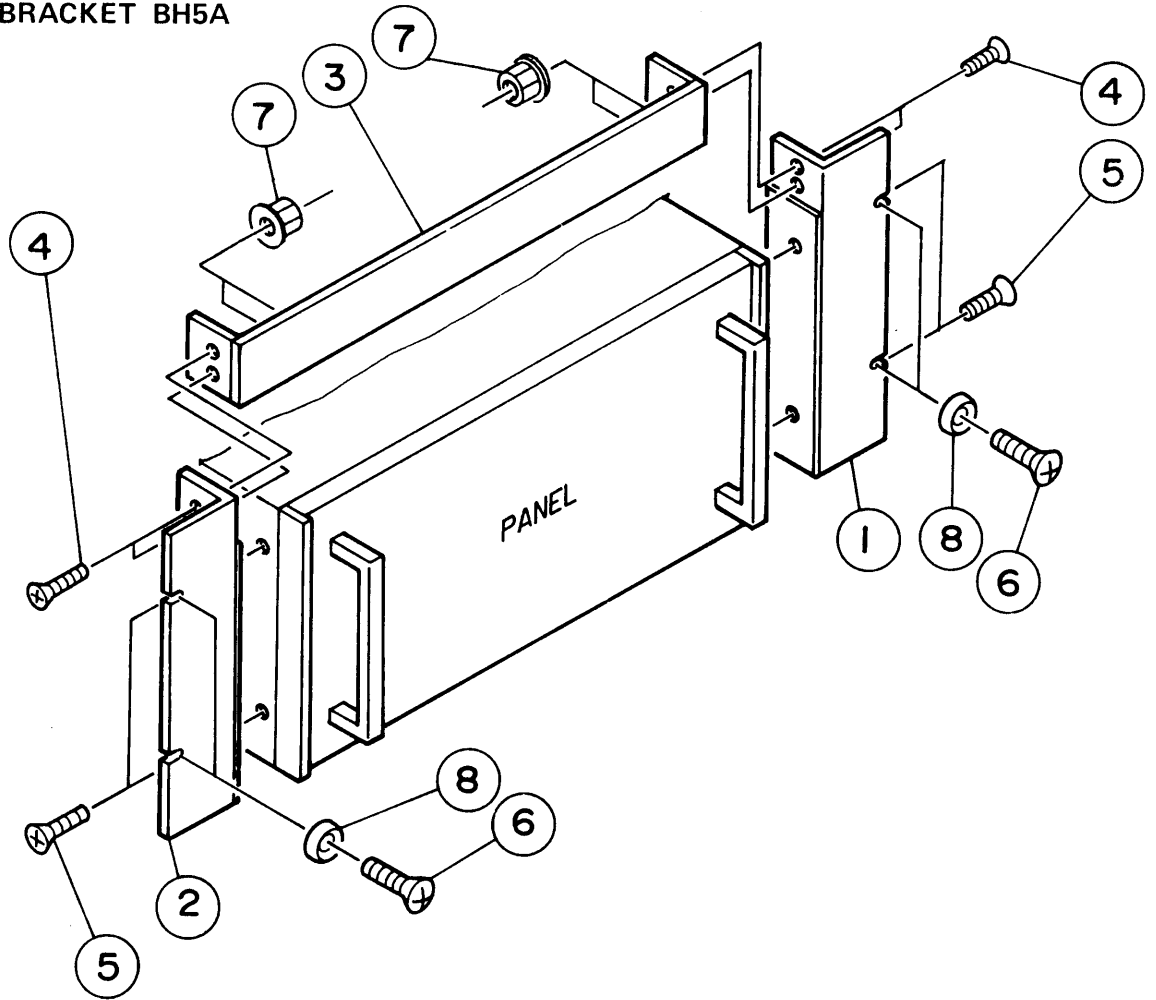

NO.	DESCRIPTION	QTY	CODE NO.
1	BRACKET RIGHT BH5A	1	D3-984-101
2	BRACKET LEFT BH5A	1	D3-984-102
3	BLANK PANEL FOR BH5A	1	D3-984-103
4	SCREW, FLAT HEAD M3x0.5x10 S-ZN	4	M2-001-101
5	SCREW, FLAT HEAD M4x0.5x16 S-ZN	4	M2-001-171
6	SCREW, OVAL HEAD M5x0.8x14 B-NI	4	M2-002-091
7	FLANGE NUT HEXAGON M3x0.5 S-ZN	4	M4-010-021
8	FINISHING WASHER 5CW	4	M5-003-031